

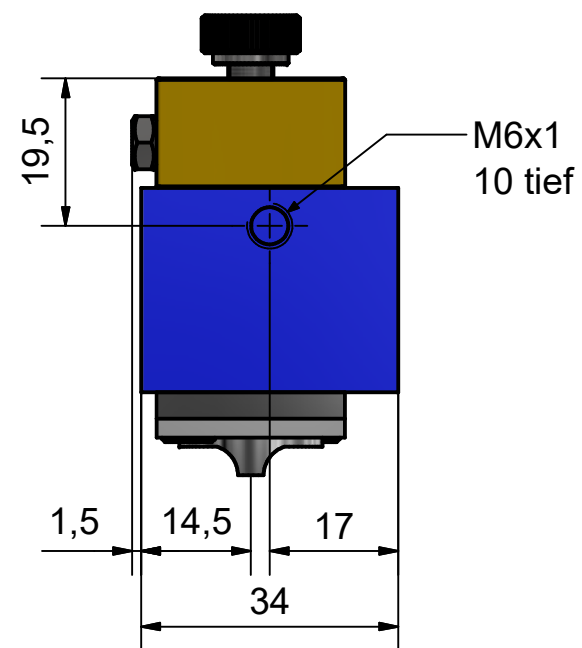

Außendüse 360° drehbar

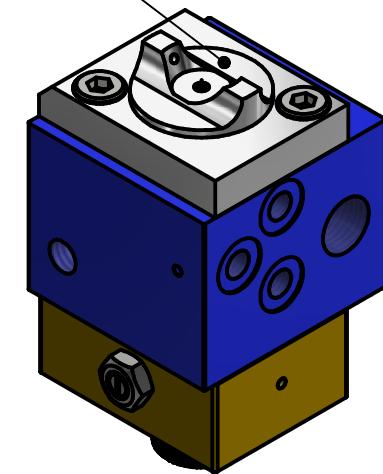

Allgemeintoleranzen DIN ISO 2768-mK			
Änderung	Ausgabedatum	Bemerkung	Artikel Nr.
A. Hiessl	15.09.2020	Einbaumaße	SPK010050
		Dokumentenart	
		Baugruppenzeichnung	
		Titel, Zusätzlicher Titel	
		HST100	
		Maßstab: 1:1	A3
 HISSL Schmiertechnik GmbH D - 72663 Grossbottlingen <small>Vervielfältigen und Kopieren nur mit unserer Genehmigung / Reproduce or copy only with our permission</small>			